

A Star for Christmas

Design by A. Rossius

This circuit acts as a simple light effects generator. With the LEDs suitably arranged, it will produce the impression of a star and so makes an ideal Christmas ornament or decorative element. As you can see from the board layout, the LEDs have been arranged in the shape of a star.

The first LED to light is the centre one. Then follow the LEDs in the inner ring (D3-D19), followed by the next ring, and so on, right up to the outer ring (D43-D50). The sequence is then started again. The speed of the light effect depends on the setting of P1.

The operation of the circuit is just as simple as the light effect produced. A 555-based

timer is configured as an astable multivibrator clocking a decimal counter (IC2). After a reset, output Q0 is activated. The next output on the counter, Q1, is activated on the next clock pulse, and so on. The counter outputs control the LEDs via buffer transistors. The seventh clock pulse causes a reset pulse and so forces the counting to start at Q0 again.

Apart from a functional circuit, an all-electronic Christmas decoration requires a suitable overall design. That's why we've designed a PCB layout with the LEDs suitably arranged in straight lines.

(020040-1)

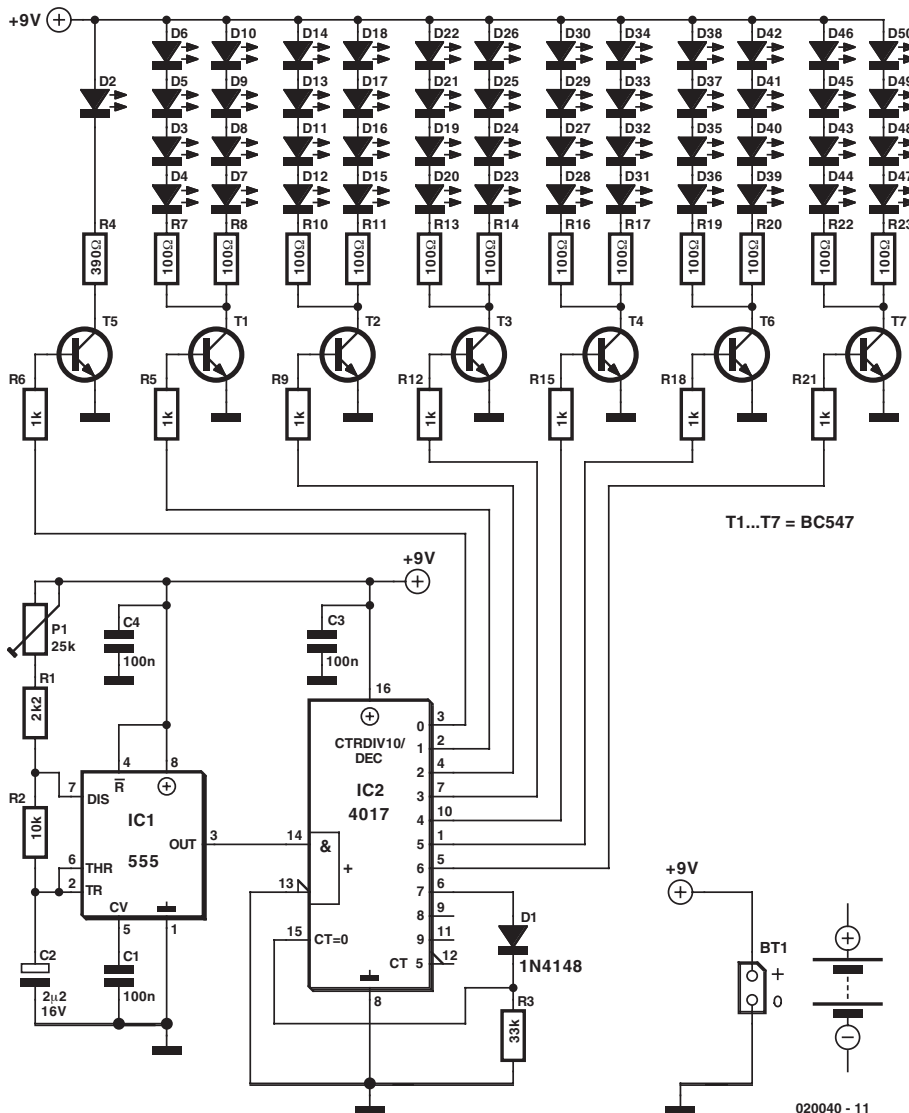

Figure 1.

COMPONENTS LIST

Resistors:

- R1 = 2kΩ
- R2 = 10kΩ
- R3 = 33kΩ
- R4 = 390Ω
- R5,R6,R9,R12,R15,R18,R21 = 1kΩ
- R7,R8,R10,R11,R13,R14,R16,R17,R19,R20,R22,R23 = 100Ω
- P1 = 25 kΩ preset

Capacitors:

- C1,C3,C4 = 100nF
- C2 = 2μF 16V radial

Semiconductors:

- D1 = 1N4148
- D2-D50 = LED, red
- T1-T7 = BC547
- IC1 = 555
- IC2 = 4017

Miscellaneous:

- 9V battery with clip-on connector

