

4-Bit Decimal Display

004

Display driver ICs are available in several standard implementations. This circuit makes use of a GAL 22V10 to drive two 7-segment displays without multiplexing. A 4-bit binary code at inputs A/B/C/D is converted to a decimal number. An example of an application is the 'Audio Limiter (for DVD)', but take note of the voltage levels! The multiplexers used there are driven by a 4-bit binary counter. This circuit will give a better indication of the behaviour and settings of the limiter.

The segments that have to light up with the various input bit combinations are shown on the accompanying table.

This table is used as the basis for writing the equations that result in the program for the GAL. Use can be made of either the max- or the min- terms depending on whichever results in the smallest number. The outputs are active low, because

they are able to sink more current than they can source. The resistors R1 through R9 are selected such that the resulting current through each of the segments is about 3mA. The displays, therefore, must be common-anode. The displays used here are very small, the characters are only 7 mm tall (the displays are 10 mm high in total). The printed circuit board is actually intended to be more of an example, because in the final application it may be more desirable to fit LD1 and LD2 on a separate PCB.

As can be seen from the table, there is an extra feature when the inputs are 0000, in which case only a single dash is displayed (segment g of LD1). When the corresponding input is left open a dash is visible (low level will give a '0'). With the aforementioned limiter this means that no attenuation is taking place.

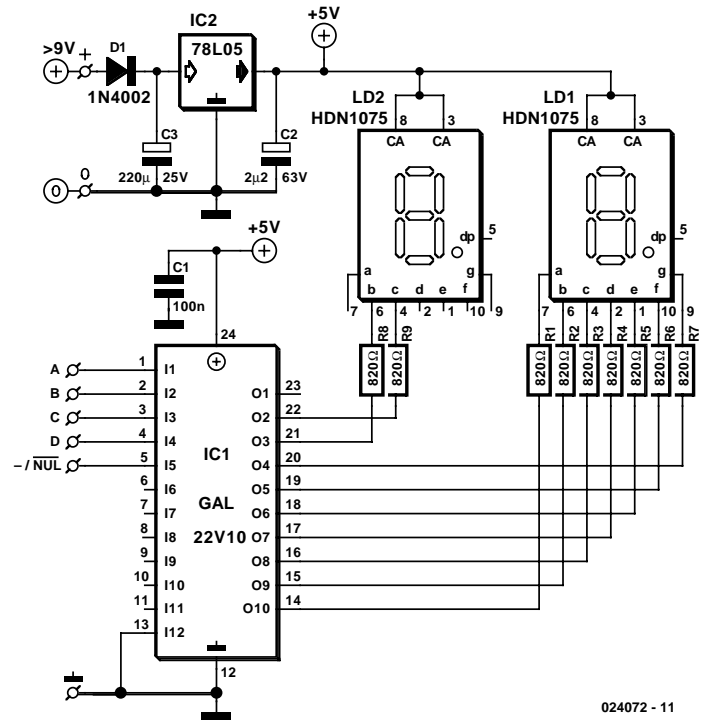
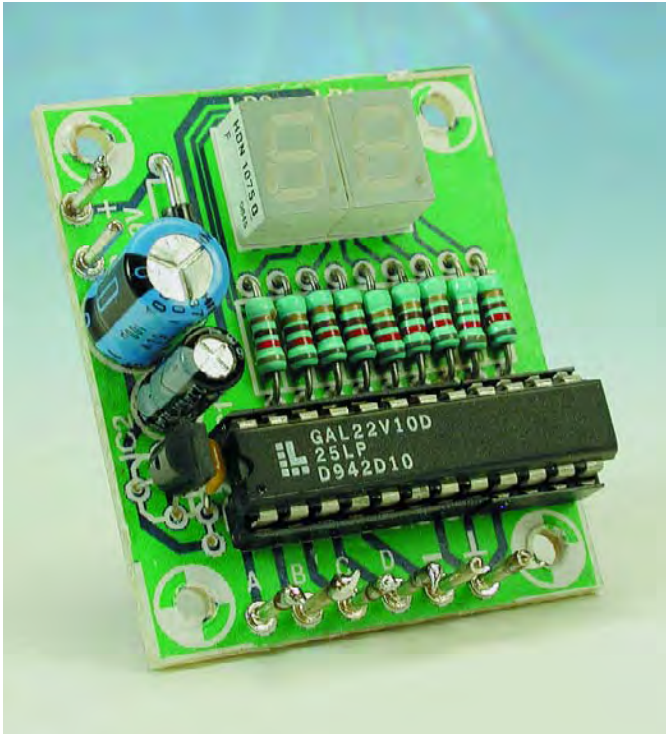

The circuit is provided with its own 5-V regulator (78L05, take note of the dissipation!) so finding a suitable power supply should not be problem. The current consumption is a minimum of about 60 mA (indication ‘-’) to about 85 mA maximum (indication ‘10’). The jedec file you’ll need to program the GAL may be obtained as a Free Download from the *Elek-*

tor Electronics website. The PCB shown here is unfortunately not available ready-made. (024072-1)

COMPONENTS LIST

Resistors:

R1-R9 = 820Ω

Capacitors:

C1 = 100nF ceramic
C2 = 2μF2 63V radial

C3 = 220μF 25V radial

Semiconductors:

D1 = 1N4002
IC1 = GAL22V10
IC2 = 78L05
LD1,LD2 = HDN1075

	b2	c2	a1	b1	c1	d1	e1	f1	g1	D	C	B	A
-	0	0	0	0	0	0	0	0	1	0	0	0	0
0	0	0	1	1	1	1	1	1	0	0	0	0	0
1	0	0	0	1	1	0	0	0	0	0	0	0	1
2	0	0	1	1	0	1	1	0	1	0	0	1	0
3	0	0	1	1	1	1	0	0	1	0	0	1	1
4	0	0	0	1	1	0	0	1	1	0	1	0	0
5	0	0	1	0	1	1	0	1	1	0	1	0	1
6	0	0	1	0	1	1	1	1	1	0	1	1	0
7	0	0	1	1	1	0	0	0	0	0	1	1	1
8	0	0	1	1	1	1	1	1	1	1	0	0	0
9	0	0	1	1	1	1	0	1	1	1	0	0	1
10	1	1	1	1	1	1	1	1	0	1	0	1	0
11	1	1	0	1	1	0	0	0	0	1	0	1	1
12	1	1	1	1	0	1	1	0	1	1	1	0	0
13	1	1	1	1	1	1	0	0	1	1	1	0	1
14	1	1	0	1	1	0	0	1	1	1	1	1	0
15	1	1	1	0	1	1	0	1	1	1	1	1	1

